

PIPELINED MULTI MODE SHIFTER

■ DATA PATH
■ CONTROL LINES

STAGE 0: INVERT INPUT

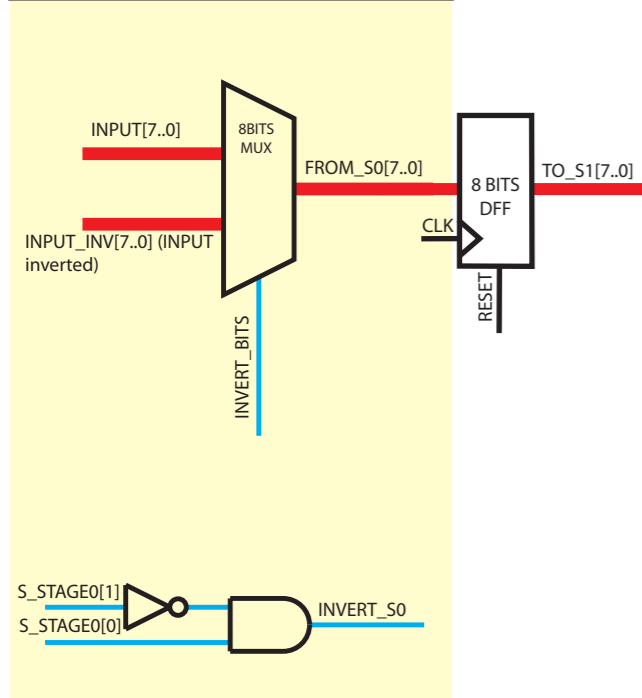

STAGE 1: SHIFT BY 1 BIT

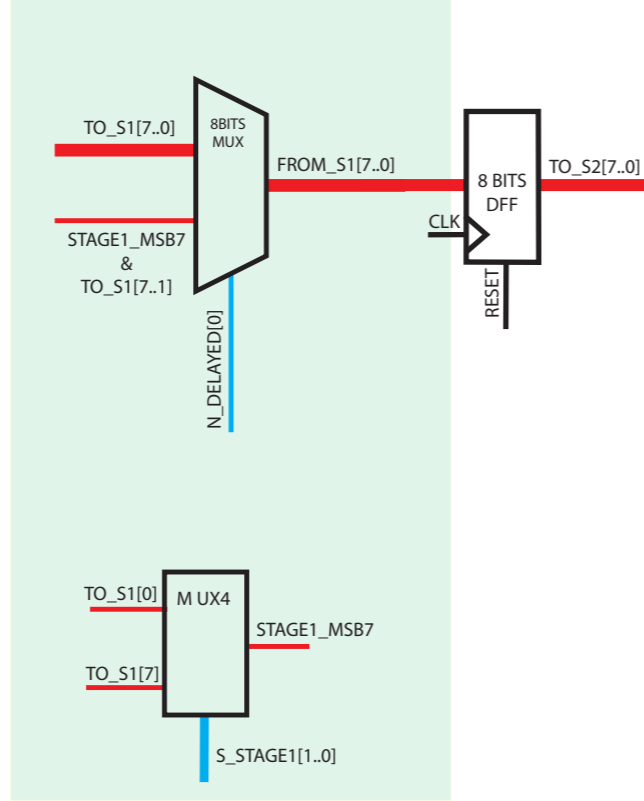

STAGE 2: SHIFT BY 2 BITS

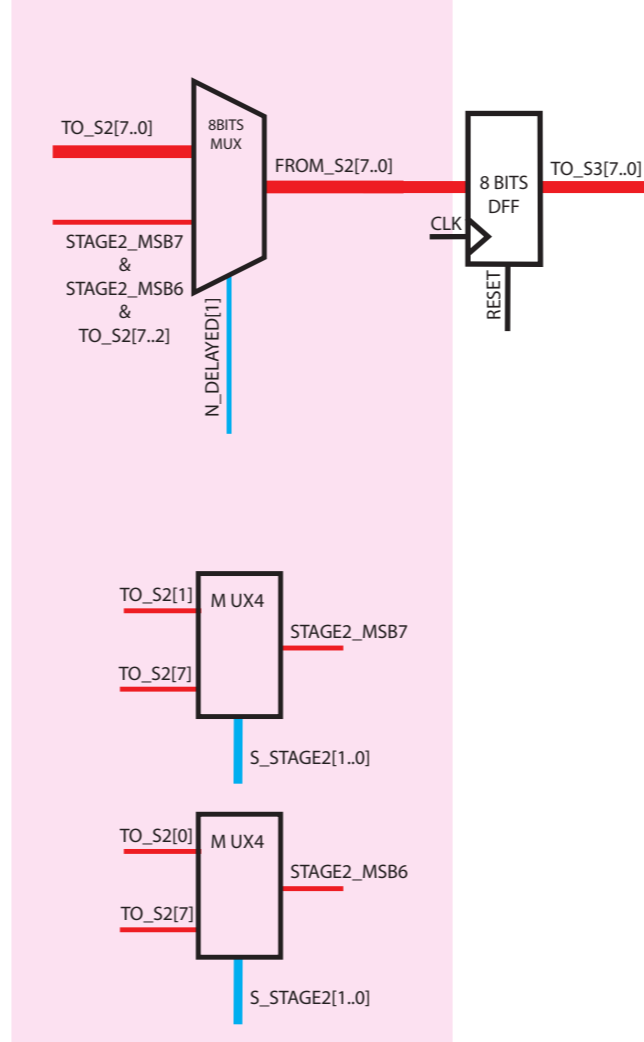

STAGE 3: SHIFT BY 3 BITS

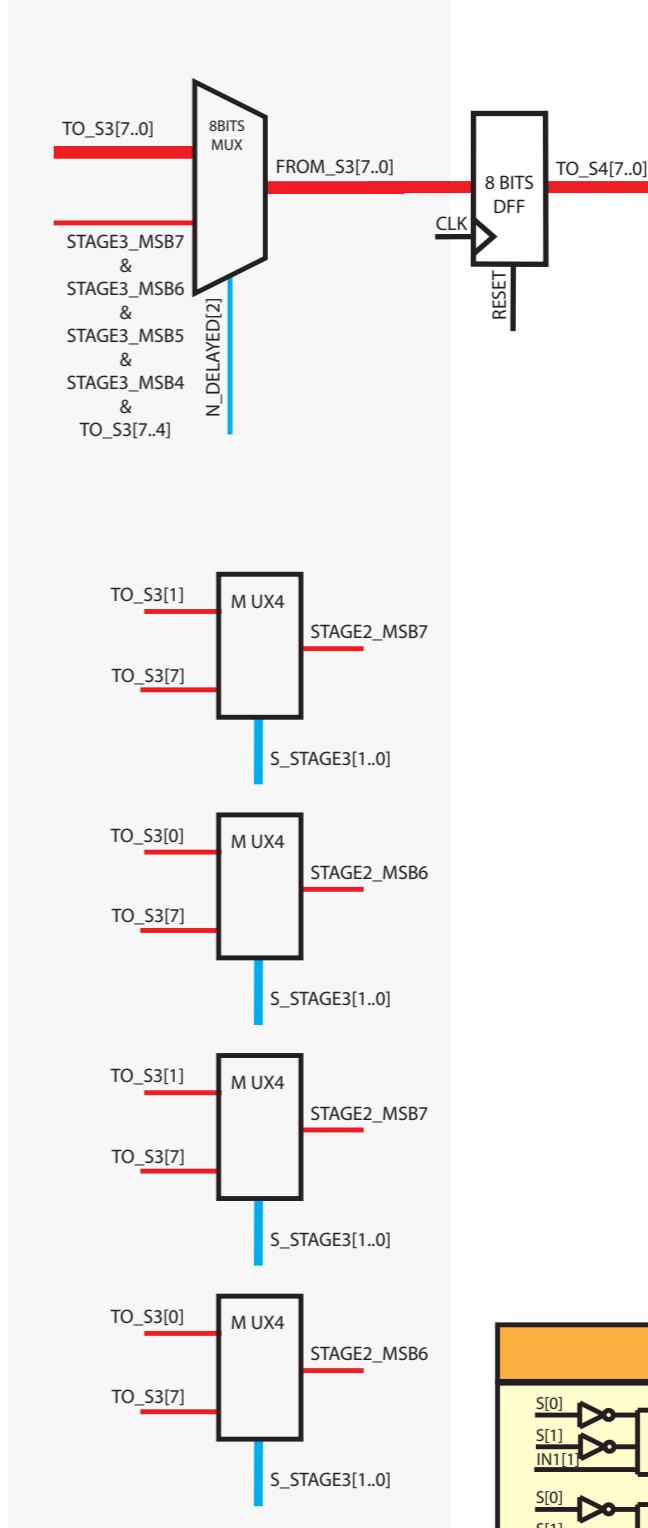

STAGE 4: INVERT OUTPUT

